



INNOVATION NEWSLETTER

++++ July 2011 +++++

Technical Innovation

The Cradle to Cradle®- Concept

The Cradle to Cradle® principle, largely developed by the German Professor Dr. M. Baumgart, is based on the belief that environmental protection can only be successful when products are developed with regard to their entire life cycle. Cradle to Cradle® therefore produces no waste products and response to the urgent challenges of our time. The Cradle to Cradle® - concept is seen as a strategy for change on the way to a new economic system in which products and processes are designed so that it need not be regulated.

The cradle to cradle concept distinguishes between two cycles:

- Biological cycle
- Technical cycle

In the biological cycle organic materials – once used – will be completely decomposed. Their

decomposition products are being used as biological nutrients. Typical materials in the biological cycle are fibers, food, and cosmetic products, which are compostable. Cradle to cradle products of the biological cycle are clothes (e.g. t-shirts from the company Trigma offering a 100% compostable T-shirt).

In the technical cycle non-toxic, non-harmful synthetic materials are used in continuous cycles with the without losing its quality. They can be used again and again instead of being "downcycled" into lesser products, and finally becoming waste. A very successful example is the office chair THINK from the American company Steelcase.

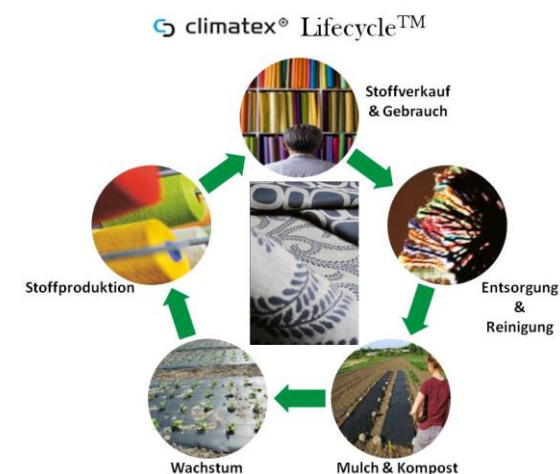

Photo: Example for the biological cycle
Source: Prof. D. M. Baumgart, Hanseatic Conference 2011, Hamburg



Photo: Example for the technical cycle
Source: Prof. D. M. Baumgart, Hanseatic Conference 2011, Hamburg

FURTHER INFORMATION:

EPEA Internationale Umweltforschung GmbH

Phone: +49-40-4313 49-0

Email: epea@epea.com

Internet: www.epea-hamburg.org



Biological treatment plants of domestic wastewater

Traidenis in Lithuania has developed 3 types of wastewater treatment plants of domestic wastewater for private houses. NV-A type: excess sludge is pumped off by the assenisation machine. NV-M type: excess sludge is pumped off into bags of dewatered sludge. NV-T type: excess sludge is pumped off into sludge separator.

NV 1÷4a type wastewater treatment plant consists of two chambers present in one tank (Figure 1). At first, wastewater, flowing into the plant, enters into the internal chamber, where it is mixed with the activated sludge with the help of air. Compressed air is necessary for supporting life of activated sludge and internal recirculation of treated wastewater. Air is provided with the help of the compressor (airblower). Biological treatment, i.e. treatment with activated sludge, is based on micro-

organisms' activities. Purpose of the process is to bind soluble, colloidal and biogenic substances from wastewater into active sludge and separate activated sludge. Flake forming microorganisms multiply and form groups that cause adherence of protozoos and other bacteria. Microorganisms metabolise ("eat up" and decompose) and destroy organic substances. Decomposition of organic materials and formation of the activated sludge takes place in the aeration section. Mixture of the activated sludge from the aeration chamber enters the external chamber (the secondary settling vessel), where, due to gravity forces, the activated sludge separates and falls down into the bottom part of the plant and the separated treated water lifts up and drains away. If the mass of microorganisms increases, the amount of the activated sludge also increases. Excess sludge is removed by the assenisation machine by pumping-off two-thirds of the plant capacity.

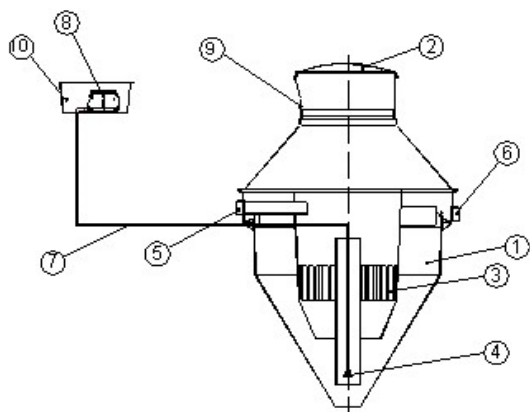

Main structural parts:

1. Body (glass-fibre)
2. Lid
3. Bioload
4. Aerator
5. Inflow pipe
6. Outflow pipe
7. Air feeding pipe
8. Airblower

Supplementary collection

9. Riser ring
10. Windblower housing

Figure: NV 1÷4a type biological treatment plant

Source: http://www.traidenis.lt/en/solutions-and-products/nva_treatment_plant.php

FURTHER INFORMATION:

Traidenis, Lithuania

Phone: +370 8 315 782 63

Fax: +370 8 315 777 29

Email: info@traidenis.lt

Internet: www.traidenis.lt

Practical application of new heating units for steam curing

The manufacturing of construction materials and structures and particularly those made of reinforced concrete (beams, floor structures, staircases, pipes, etc.) requires heat and wet treatment in compliance with a certain program. As a rule, water steam with low parameters (temperature of up to 100°C and higher than atmospheric pressure) is used; it is produced by steam generators of industrial boiler houses. The power generation in this case suf-



fers from low efficiency (extensive heat leakage in the boilers and steam pipes) and huge capital expenses (boiler houses, flue funnels, heating mains).

The company of A.P. Petushkov builds in cooperation with the Brest Technical University steam-and-gas generators for decentralized heat supply of steam curing chambers at enterprises manufacturing reinforced concrete structures. A steam-and-gas generator makes boiler houses and related installations redundant. It produces an appreciable economic effect for small enterprises and particularly for standalone steam curing chambers.

A steam-and-gas generator is basically a water container which contains a high-power flame unit working on a combustion resonance principle. The water cooling the unit turns into steam which mixes with the combustion products. The latter are burnt completely. Therefore the resulting mix - pure steam-gas - is fed into the steam curing chamber. Small dimensions and simplicity of maintenance make it possible to install the steam-and-gas generator at the steam curing chamber shop.

Introduction of the steam-and-gas generator at Brest-based construction facility No. 8 and at construction department No. 262 made it possible to continue the manufacturing process even in winter; previously the facilities had to suspend their operations because regular heat generators failed to deliver the required performance.

The steam-and-gas generator was built in minimal technological conditions and installed more than a year ago at the steam curing chamber. It started operating shortly afterwards. The personnel that had no previous training in power generation quickly learnt to

operate the generator. Fine tuning and maintenance presented no troubles whatsoever. In order to keep the costs down we almost completely avoid using any automatic equipment. It was easy to observe the safety regulations: the generators stops - no sound is produced - emergency shutdown is initiated (manual or automatic fuel cutoff).

FURTHER INFORMATION:

Leana Khaladar

Head of Technology Transfer Center
Brest State Technical University
267 Moskovskaja Str.,
224017 Brest, Republic of Belarus
Phone/fax: +375 162 408374
Email: lihodar@bstu.by

Tradition drier installation for sawn timber

Professor V.S. Severjani from the Brest State Technical University has constructed a drier installation for sawn timber. It consists of a drying chamber with air ducts, a container and furnace with an air heater. The main peculiarity is that the wooden boards and bars are placed "edgewise" resulting in the overall compression of the entire pile. This makes it possible to boost the drier efficiency by 20-50% without any deterioration of the timber quality. It can be made mobile and manufactured as a portable unit for small wood processing enterprises and stand-alone drying facilities. Uses waste wood as fuel.

The Brest State Technical University offers their advice in designing and implementing the above mentioned technical proposal. They will take care of all legal and patent aspects will develop and disseminate promotional material.



FURTHER INFORMATION:

Leana Khaladar

Head of Technology Transfer Center
Brest State Technical University
267 Moskovskaja Str.,
224017 Brest, Republic of Belarus
Phone/fax: +375 162 408374
Email: liholodar@bstu.by

Best Practice

Filigree - from tradition to modern design

Filigree originates in the two latin words filum, meaning threads and granum, which means corn. So working inside the filigree craft is about using threads and grains.

The craft of filigree goes way back in all civilizations. During the Renaissance, filigree spread all over Europe, to Norway and even into remote, small villages.

Today, filigree is in use when making silver ornaments for the national and local costumes various parts of Norway, worn by locals at the grand occasions. The Telemark Region has a reputation for very high quality, multiple layers of details and no open space in the jewelry.

Gry is very proud to be part of this tradition!



Photo: Jewelry from Gry's collection

The filigree is linked to the goldsmith craft, passing traditional patterns through genera-

tions of master craft generations, thus enabling the masters to modify and invent new designs and patterns, and pass them on to the next generations.

For Gry m. Grindbakken the challenge is to take my heritage of filigree craft, bound by rules and symmetry, and merge it with the demands of new generations of modern customers. It is a big challenge to respect the traditions and look to the world of today at the same time. Thus, the vision for Gry's business is "Traditional filigree to modern people".

Gry feels confident in her use of traditional craft knowledge, it makes her better equipped to meet customers with modern preferences.

Nowadays many parents buy their children a traditional costume about the age of fifteen, often as a gift for the children's first communion. The traditional handmade filigree-brooches, which come with it, are expensive. Some people chose this silver jewelry regarding only the price, which give an advantage for mass produced models - my hardest competitors.

It is a challenge to mark the value of handmade jewelry, but the situation is improving and Gry's business results with it. She lives in a constant struggle to reduce time spent on each operation leading to an individually made piece of filigree jewelry and simultaneously motivate for the use of real handmade art craft.

FURTHER INFORMATION:

Gry M. Grindbakken, Filigransarbeider, Norway

Phone: +47 99 79 78 99

Email: gry@fili.as

Internet: <http://www.fili.as>

Facebook: <https://www.facebook.com/pages/Fili/338040392120?ref=ts>



Small Business Act – new brochure

The European Commission (Enterprise and Industry) has recently published a new brochure about the Small Business Act. The Small Business Act aims at improving the overall approach to entrepreneurship, permanently anchor the 'Think Small First' principle in policy making from regulation to public service, and to promote SMEs' growth by helping them tackle the remaining problems which hamper their development.

The brochure focus on what the EU does for SMEs and is available in any language of the European Union.

FURTHER INFORMATION:

European Commission

http://ec.europa.eu/enterprise/newsroom/cf/itemlongdetail.cfm?item_id=5256#

Projects

Baltic Supply – “getting started services”

The Baltic Supply project, part-financed by the European Union, is aiming at creating better business opportunities for the many Small and Medium Sized (SMEs) businesses located in the Baltic Sea Region. The project partners recently started to develop getting started services, which will be provided on an internet platform. The platform will support SMEs in the Baltic Sea area as well as in the North Sea area to find cooperation partners, get information about train-



ings and download information materials, and contact persons in the region.

The getting-started services defined so far are:

- Technology transfer network for the energy sector
- Technology transfer network for the food sector
- Cluster promotion activities
- Matchmaking tools, event concepts
- Management trainings
- E-learning tool for SMEs
- Company profiles/registry
- Guideline “information about regional competences”
- Tender management service

We will keep you informed about the progress of the project and the launch of the website in the innovation newsletter.

FURTHER INFORMATION:

Kerstin Kötschau, Hanse Parlament, Hamburg

Email: Kkkoetschau@hanse-parlament.eu

Upcoming Events

September 7-10, 2011 in Riga:

Food exhibition “Riga Food”

Riga Food is the biggest food industry exhibition in the Baltic countries that shows the development of industry in general, highlights novelties and gives an





opportunity to meet serious and reliable food industry enterprises.

The Riga Food exposition is divided in thematic zones in order to provide favourable conditions for beneficial networking to both the participants and visitors of the exhibition:

- Riga Food Regular Expo
- Riga Food Drinks
- Riga Food Gourmet
- Riga Food Specialty
- Riga Food Printing and Packaging Tech
- Riga Food Technology And Ingredients
- Riga Food Catering And Retail Tech
- Riga Food Hotel Expo
- Riga Food Clean Expo
- Riga Food Innovation

FURTHER INFORMATION:

www.bt1.lv/bt1/rigafood/

September 13, 2011 in Bremen:

Matchmaking at 9th German Foreign Trade Congress

In 2011 Bremen will welcome participants already to the 9th German Foreign Trade Congress. With its combined competence in the high tech sector, foreign trade and logistics, the hanseatic city is an outstanding address for discussion on the future of exports.

Matchmaking at the 9th German Foreign Trade Congress is an ideal event to make contacts and to prepare future business. It will allow participants to get together with the most promising business partners in pre-scheduled meetings. Here you present your company and identify attending participants. Register yourself now, and in just one day you will be able

to run into numerous discussions with representatives of foreign trade businesses, saving you time-consuming business trips.

FURTHER INFORMATION:

Matchmaking:

<http://www.b2match.eu/awt2011>

German Foreign Trade Congress:

http://www.aussenwirtschaftstag.de/auwi.php?nav=1&sub1=0&sub2=0&menu_id=2

21.-22.10.2011 in Panevėžys:

Business- Forum on Construction Technology

The business forum aims at directors, leaders and employees of small and medium- sized enterprises in order to

- initiate international business contacts between companies and

- provide information about new technologies.

SMEs from all over the Baltic Sea Region are invited to this event. Language skills are not necessary (simultaneous translations). The participation is free of charge. Participants must carry travel and accommodation costs.

FURTHER INFORMATION AND REGISTRATION:

Secretary of the Hanseatic Parliament:

www.hanse-parlament.eu

Email: info@hanse-parlament.eu

Part-financed by the European Union (European Regional Development Fund and European Neighbourhood and Partnership Instruments).

